



Roomba

...smart
...simple
...clean



User Manual

Table of Contents

Roomba Anatomy.....	page 2-3
Charging Roomba.....	page 4
Cleaning with Roomba.....	page 5
Roomba Features	page 6-7
Roomba Maintenance.....	page 8-9
Virtual Walls	page 10
Frequently Asked Questions.....	page 11
Contact iRobot Corporation	page 12

Roomba Anatomy

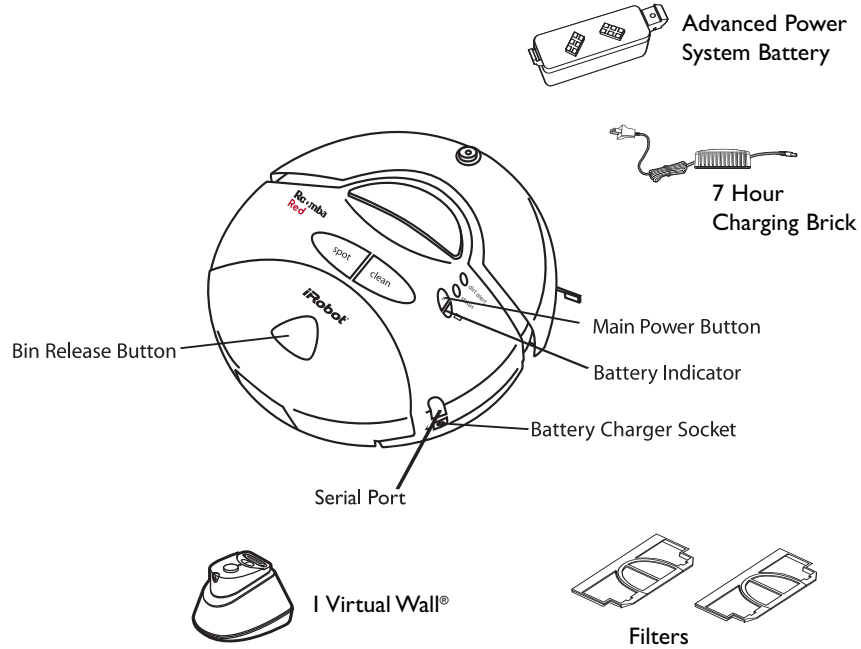

Roomba Anatomy

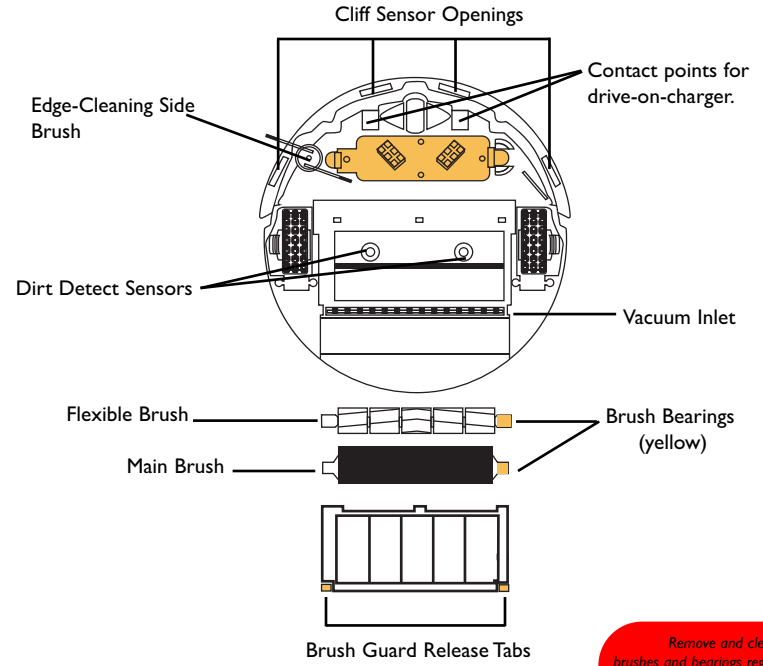

Remove and clean the brushes and bearings regularly to ensure optimal cleaning performance. See pg. 8

Charging Roomba

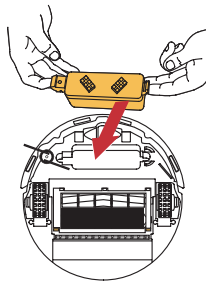

You need to charge Roomba before cleaning for the first time.

- 1 Place APS battery into Roomba Robotic Floorvac. Press down on both ends.

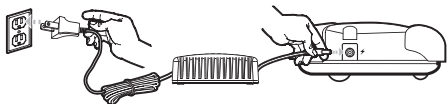

- 2 Plug the charger directly into Roomba.

Color of Battery Indicator	Battery Status
Pulsing Amber	Charging
Green	Fully Charged
Amber	Partially Discharged
Red	Almost Fully Discharged
Flashing Red	Fully Discharged

- 3 Charge for 7 hours.
- 4 Power light will turn solid green to indicate a full charge.
- 5 Unplug the charger and press clean.

- 6 Roomba will run for up to 120 minutes on hard floors. Run times may vary based on floor surface.

For best battery performance, always keep Roomba plugged in.

Cleaning with Roomba

Cleaning Pattern

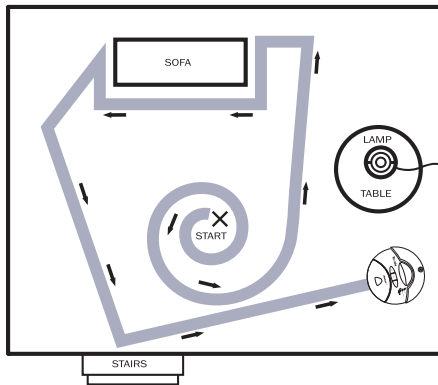

Before cleaning with Roomba, clear the floor of loose objects. If you don't use Roomba over it (e.g., rug tassels, power and blind cords).

Roomba will clean based on the cleaning mode you select. Roomba has two cleaning modes:

Clean mode - Roomba automatically calculates the room size and adjusts its cleaning time appropriately. Roomba may clean for up to 60 minutes.

Spot mode - Roomba will spiral approximately 3 feet in diameter and then spiral back to where it started, intensely cleaning a localized area.

You can use a Virtual Wall to block off areas you don't want Roomba to enter. (See page 10)

Roomba Features

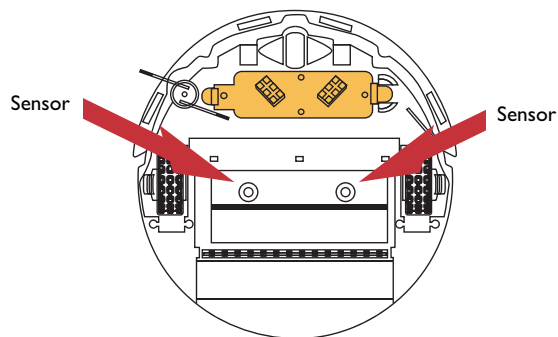

Dirt Detect Mode

Roomba features the ability to clean more intensely in dirty areas. When Roomba finds a particularly dirty area you will see the blue Dirt Detect light come on and Roomba will change its cleaning pattern.

Roomba uses two sensors to recognize the dirtiest areas. To ensure optimal performance, you may want to periodically wipe the sensors with a dry cloth. Roomba will sense heavy debris like pepper, sand, and rice. Roomba will not sense pet hair or dust, but will pick them up.

Roomba Features

Mission Status:

At the end of a cleaning mission, Roomba will tell you if it has successfully completed its mission.

Roomba Stops for 3 reasons

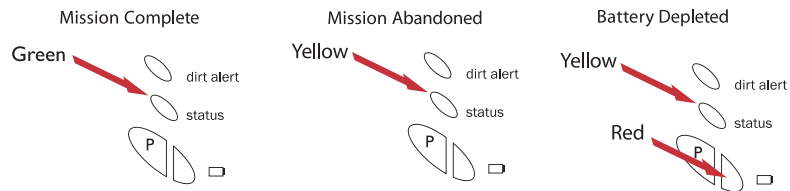

If Roomba's mission is abandoned, always make sure the brushes and bearings are clean.

Roomba Maintenance

There are a few things you can do to keep Roomba running at peak performance.

- 1 Empty the bin over trash barrel after each use.

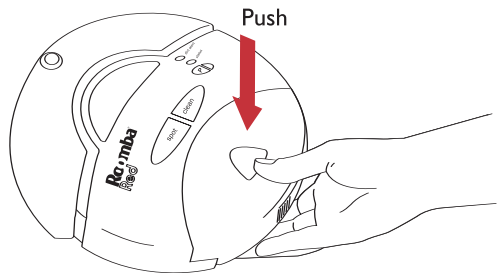

- 2 Remove and clean the brushes every 5 uses.

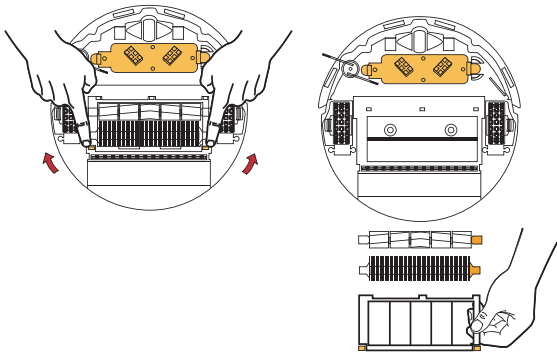

8

Roomba Maintenance

- 3 Empty the filter compartment after each use.

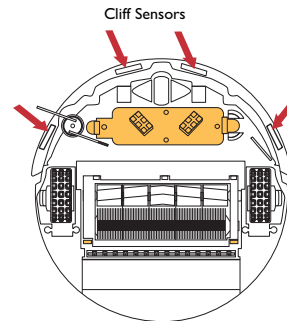

- 4 Inspect & clean sensors.
(when you clean brushes)

- 5 Inspect the vacuum inlet and clean debris as needed.

- 6 Periodically change Roomba's filter:

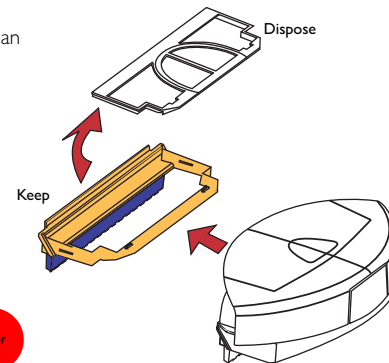

9

Roomba Accessories

Virtual Wall

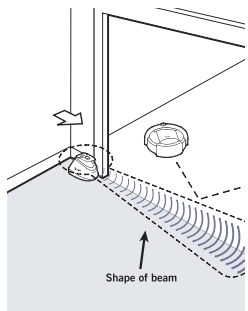

Virtual Walls create a keyhole shaped area that Roomba will not enter. Virtual Walls are great for keeping Roomba in or out of rooms, or away from cords and other spots you don't want Roomba to clean.

Virtual Walls will automatically shut off after approximately 130 minutes.

You can set Virtual Walls to block areas up to 13 feet wide. Remember, at 13 feet, the far end of the beam will be very wide.

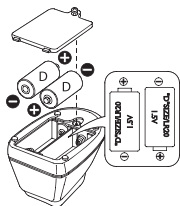

Frequently Asked Questions

What can I do if Roomba's battery does not seem to be charging?

If Roomba's battery is not charging, you should first make sure it is properly seated in Roomba. When you insert the battery, you should hear two clicks. Then confirm that the green light on the charging "brick" is a solid green and that the power indicator light is pulsing. If this does not work, call customer service at 877-855-8593.

What should I do if Roomba repeatedly starts and stops, or just spins in place?

If Roomba is repeatedly starting and stopping, or just spinning in place, you may have a blocked cliff sensor. Try cleaning the cliff sensors, located under the bumper, with a Q-tip or compressed air. You also should remove and clean Roomba's brushes and brush bearings.

What can I do if Roomba is cleaning longer than I'd like in a particular room?

Roomba automatically calculates room size and run time based on a number of factors. Roomba will clean for longer in rooms with more debris and furniture. Roomba also spends a little bit longer cleaning rugs than hard floors. In an empty 8x10 room with hard floors, Roomba will clean for approximately 20 minutes. Removing obstacles from a room will decrease the amount of time Roomba needs to spend in a room.

The Roomba Robotic Floorvac is easy to use,
but under the hood it's a complex robot. We're
Roboticians, your retailers are not. If you have
questions or comments, we're anxious to help,
please visit us at
www.irobot.com
or
call 877-855-8593

iRobot, Roomba, Roomba Discovery, Virtual Wall are trademarks of iRobot Corporation.

© 2005 iRobot Corporation. All rights Reserved

US Pat Nos 6,594,844; 6,690,134 and 6,809,490. Additional Patents Pending
Burlington, MA 01803

Version: 4100-V2